

## Náboje s přírubou

podle DIN

- Materiál: ■ ocel 16MnCrS5Pb/C45  
 ■ bronz Rg7  
 ■ nerezová ocel 1.4305

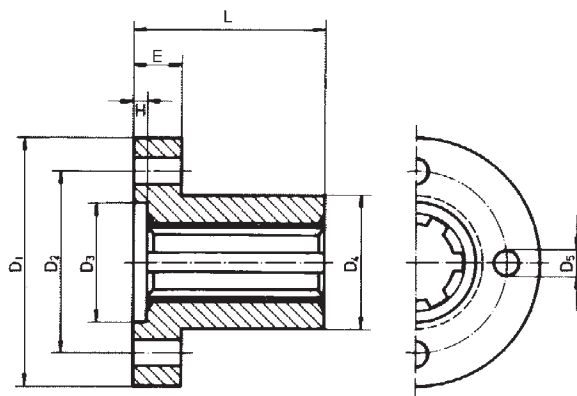

Objednáací číslo Materiál: ocel	Objednáací číslo Materiál: Rg7	Objednáací číslo Materiál: 1.4305	D <sub>1</sub>	D <sub>2</sub>	D <sub>3</sub> H7	D <sub>4</sub>		D <sub>5</sub>	E	L	H	Hmotnost	
						h8	h9					Ocel [kg]	Bronz [kg]
KN11	KN11R	KN11SS	42	28	20	–	20	4,5	8	35	3,0	0,10	0,12
KN13	KN13R	KN13SS	50	36	22	–	25	4,5	8	40	3,0	0,18	0,22
KN16	KN16R	KN16SS	52	38	25	–	28	5,5	10	40	3,0	0,22	0,26
KN18	KN18R	KN18SS	54	40	30	30	–	5,5	10	45	3,5	0,26	0,30
KN21	KN21R	KN21SS	62	48	35	–	34	6,6	10	50	3,5	0,34	0,38
KN23	KN23R	KN23SS	64	50	36	36	–	6,6	10	55	3,5	0,41	0,47
KN26	KN26R	KN26SS	70	56	40	–	42	6,6	10	60	3,5	0,50	0,58
KN28	KN28R	KN28SS	78	60	46	45	–	9,0	12	60	3,5	0,64	0,74
KN32	KN32R	KN32SS	82	65	50	–	50	9,0	12	60	3,5	0,72	0,84
KN36	KN36R	KN36SS	90	70	52	52	–	9,0	16	80	4,0	0,94	1,07
KN42	KN42R	KN42SS	95	75	60	–	60	11,0	16	80	4,0	1,22	1,38

## Svěrné kroužky

podle DIN

- Materiál: ■ ocel 16MnCrS5Pb/C45  
 ■ bronz Rg7  
 ■ nerezová ocel 1.4305

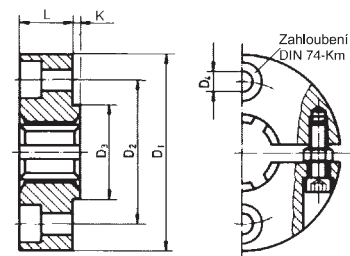

Objednáací číslo Materiál: ocel	Objednáací číslo Materiál: Rg7	Objednáací číslo Materiál: 1.4305	D <sub>1</sub>	D <sub>2</sub>	D <sub>3</sub> h8	D <sub>4</sub>	Závit	L	K	Hmotnost	
										Ocel [kg]	Bronz [kg]
KR11	KR11R	KR11SS	42	28	20	4,5	M4	12	2	0,10	0,12
KR13	KR13R	KR13SS	50	36	22	4,5	M4	12	2	0,16	0,18
KR16	KR16R	KR16SS	52	38	25	5,5	M5	14	2	0,18	0,20
KR18	KR18R	KR18SS	54	40	30	5,5	M5	14	3	0,20	0,23
KR21	KR21R	KR21SS	62	48	35	6,6	M6	14	3	0,24	0,28
KR23	KR23R	KR23SS	64	50	36	6,6	M6	15	3	0,26	0,30
KR26	KR26R	KR26SS	70	56	40	6,6	M8	15	3	0,34	0,40
KR28	KR28R	KR28SS	78	60	46	9,0	M8	18	3	0,47	0,54
KR32	KR32R	KR32SS	82	65	50	9,0	M8	18	3	0,52	0,62
KR36	KR36R	KR36SS	90	70	52	9,0	M8	18	3	0,62	0,72
KR42	KR42R	KR42SS	95	75	60	11,0	M8	22	3	0,82	0,94